

Understanding the Power Rating of Caddock MP9100 Resistors

Understanding the Power Rating

The maximum power rating of the Caddock MP9100 (TO-247 type) resistor is specified with the ceramic surface maintained at 25°C using the same method established and proven by power semiconductor manufacturers over many years.

Caddock's careful design practices and thorough reliability testing assure the user that the part will perform to all published specifications as long as its case temperature (T_C) does not exceed that specified in Figure 1. Surge ratings must be observed.

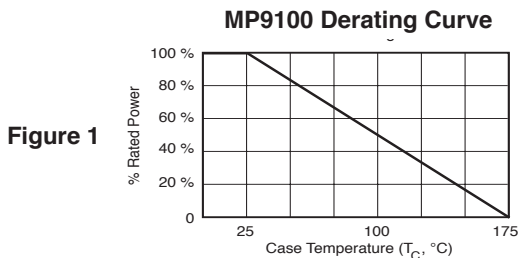

In high power applications, the actual power dissipation capability of the resistor will be greatly dependent on the heat sink, mounting method, interface ma-

terial characteristics and ambient temperature, (T_A). The maximum continuous power rating (100 Watts) for the Caddock MP9100 resistor is based on a case temperature (T_C) of 25°C measured at the center of the exposed ceramic surface. The Caddock MP9100 resistor has a thermal resistance of 1.5°C/watt ($R_{\theta JC}$), from the junction (resistor film) to the case (exposed ceramic case interface). For a case temperature (T_C) above 25°C, derating is necessary.

Allowable power dissipation (P_D , watts) may be determined by the following equation.

$$\text{Equation 1 } P_D = \frac{T_J - T_A}{(R_{\theta JC} + R_{\theta CS} + R_{\theta SA})}$$

Using the information provided in Fig 2, allowable power dissipation and temperature gradients can be estimated. Typical thermal resistance of various materials can be found in Table 1 on the next page. It should be noted that material characteristics are those provided by the manufacturers and these can vary greatly if careful manufacturing processes are not observed. Caddock suggests that actual temperature measurements should be made under worst case conditions to assure maximum reliability of a design.

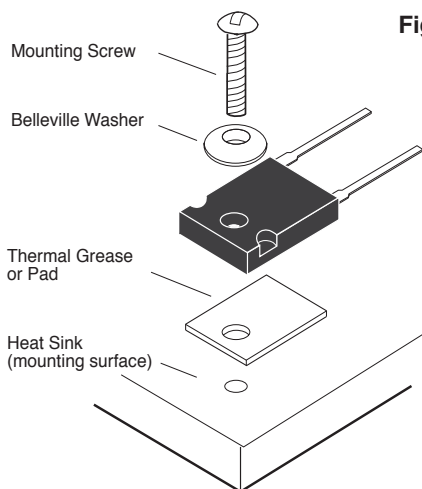
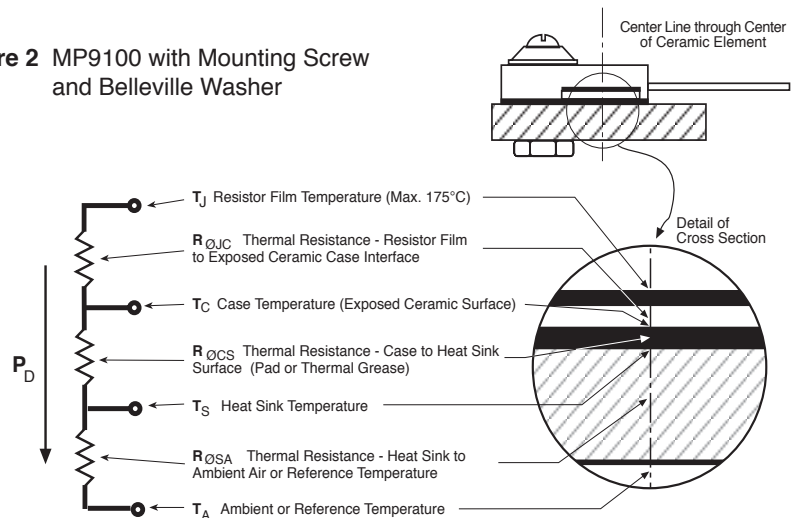

Figure 2 MP9100 with Mounting Screw and Belleville Washer



Calculation Examples

Using Equation 1 and data from Table 1, the allowable power can be determined for given ambient conditions. Assuming a maximum ambient air temperature of 50°C with the part mounted using thermal grease on an aluminum chassis, the allowable power can be calculated from Equation 1 as follows:

$$P_D = \frac{T_J - T_A}{(R_{\theta JC} + R_{\theta CS} + R_{\theta SA})}$$

$$P_D = \frac{175^\circ\text{C} - 50^\circ\text{C}}{(1.5^\circ\text{C/W} + 0.5^\circ\text{C/W} + 2^\circ\text{C/W})}$$

$$P_D = \frac{125^\circ\text{C}}{4^\circ\text{C/W}}$$

$$P_D = 31.25 \text{ watts}$$

The same part, mounted on a water cooled heat sink providing a constant 50°C reference temperature, will dissipate more than twice this amount of power.

$$P_D = \frac{175^\circ\text{C} - 50^\circ\text{C}}{(1.5^\circ\text{C/W} + 0.5^\circ\text{C/W})}$$

$$P_D = 62.5 \text{ watts}$$

Surge and Pulse Ratings

Surge or pulse voltages can be a factor in design reliability. The following guidelines should be followed.

1. Do not exceed 750 volts peak.
2. Use the following guidelines for maximum pulse energy of a single pulse.

Pulse Width	Energy (1 J = 1 Watt second)
10 μsec	0.07 J
100 μsec	0.25 J
1 msec	0.90 J
10 msec	3.5 J
100 msec	15 J

3. Accumulated pulse energy delivered in each second should not exceed allowable average power. Derate the pulse energy using the Derating Curve (Figure 1) based on estimated case temperature.

4. Above 100 msec to 5 seconds, the overload rating is 1.5 times the allowable power of the resistor in the application.

Mounting Configurations

Mounting pressure, surface cleanliness, surface flatness and surface finish are just a few of the variables which can have considerable effect on temperature rise and power dissipation. Caddock recommends an ideal spring mounting force of 4 to 15 pounds, or a typical mounting screw torque of 6 to 8 in - lbs which should provide 150 to 300 pounds of force. If a screw is used, Caddock recommends the use of a good thermal grease in conjunction with a #6 Belleville washer compressed to 50% of its normal height. These washers (p/n 04CSB52200F004) are available from Arizona Hydrogen, phone number 602-275-4126.

Table 1 Typical Thermal Resistance of Various Materials Used for High-Power Designs with Caddock MP9100 Resistors

Resistor Type	R _{θJC} (°C/W)
Caddock MP9100 (junction to case)	1.5

Interface Material (thickness)	R _{θCS} (°C/W)
Solder (0.010")	0.1
Epoxy (0.010")	1.0
Filled Epoxy (0.010")	2.5
Thermal Grease (0.003")	0.5 to 2
Q-Pad II (0.006")	0.9
SIL-PAD 400 (0.007")	3.1
SIL-PAD 2000 (0.015")	1.7
Thermal Clad ® dielectric (0.003")	0.4
FR-4 / G-10 printed-circuit board (0.063")	20 to 65
Aluminum (0.063")	0.1
Copper (0.063")	0.06
Steel (0.063")	0.5
96% Alumina (0.030")	0.36
Aluminum Nitride (0.030")	0.1
Beryllia (0.030")	0.05

Typical Mounting Surfaces to Ambient Air	R _{θSA} (°C/W)
7" X 5" X 2" 0.040" Aluminum chassis	2
Small Finned Sheet Aluminum heat sink (convection)	2.0
Small Finned Sheet Aluminum heat sink (200 LFM Airflow)	1.0
4.5" X 3" X 3" Mult-Finned Extruded Aluminum (convection)	1.5
4.5" X 3" X 3" Mult-Finned Extruded Aluminum (200 LFM)	0.8

CADDOCK